

## RAPID EYE™ MULTI-MEDIA DSP

www.honeywellvideo.com

### EVENT-DRIVEN DIGITAL RECORDING AND TRANSMISSION

Rapid Eye™ Multi-Media DSP is the newest addition to the Rapid Eye Series of 16-channel digital video recorders featuring real-time recording and live local viewing. The system is designed to record, search, and transmit video, audio, and data transactions while simultaneously providing users with both live and post event evaluation.

Benefits of the system include superior live video images, dramatically improved recording rates and images, event-driven accelerated response recording and increased internal storage capacity up to 2 TB. Expanded hardware capability includes 8 user definable serial ports allowing direct connection of PTZ telemetry wiring to the unit without the need for separate hardware devices and POS capability of up to 16 data streams. The hierarchal site tree allows user definable grouping of sites and supports multiple levels of nesting within a site branch. The new Rapid Clip feature makes remote clip generation fast and easy.

#### Market Opportunities

Video Verification and a sophisticated integration with existing physical security infrastructure, such as Alarm Panels, Access Control and Central Station Alarm Monitoring are hallmarks of the new Rapid Eye Multi-Media DSP system. For retail markets, its built-in data capture capability makes it extremely useful as a loss prevention analysis tool. Whether the market is commercial, industrial, municipal, financial, or retail; when the need is for remote video surveillance the solution is Rapid Eye Multi-Media DSP.



#### Features

##### Hardware

- Real-time recording rates at CIF resolution: 480/400 global (NTSC/PAL)
- Live viewing using LocalView
- 4 shock mounted field replaceable hard drive bays
- Optional CD-RW drive for local clip generation
- 16 Looping Video Inputs
- Dual Audio Channels (Bi-directional and VoIP)
- 16 Alarm Inputs
- 8 Control Outputs
- Fault Relay (Alarm panel ready)
- 10/100 Network (standard RJ-45)
- Internal Modem
- 10 Serial Ports
- VxWorks™ – secure, stable multi-tasking real-time OS

##### Software

- 100% compatible with all previous Rapid Eye Multi systems V2 and higher
- Resolutions: selectable per camera – independently for live or recording
- Event-driven response recording – 64 user definable rules
- Enhanced PTZ control and configuration
- Expanded POS capability up to 16 devices
- Hierarchical site tree – group by region, location, etc.
- TCP/IP Port Forwarding – multiple units share an IP Address
- DHCP requires DHCP Server and WINS/DNS services
- SNTP client automatically synchronizes to SNTP servers
- RapidSearch™ for video evidence by Events, Data, Motion or Alarm

## RAPID EYE™ MULTI-MEDIA DSP

www.honeywellvideo.com

### FEATURES

The system consists of three major components which include:

- **Recorder Unit (RU)**, featuring DSP powered real-time recording at CIF resolution and the **LocalView** interface
- **ADMIN Software**, the workstation/server-based administration tool capable of enterprise-wide site and user management
- **VIEW Software**, a feature-rich, workstation-based remote operator program

The combination of ADMIN and VIEW combined with the DSP powered RU truly differentiates the Rapid Eye system from the competition.

#### LocalView

- Real-time Live video – display a single camera or all 16 cameras simultaneously
- PTZ control – Vector driven within a video stream or full featured via PTZ controller icon
- Interactive user controllable accelerated recording rates (Boost)
- Public Display mode provides a simple cost effective solution for public view monitoring
- Review recorded video, audio and data or create evidence clips using Clip Builder tab
- Review evidence clips using Clip Player tab
- Basic system and camera configurations can be defined using System tab
- Four levels of password protected user access and control

#### ADMIN Software

- HRM7ADMIN  
(single license included with RU, can also be ordered separately)
- Capable of enterprise-wide site, user, tour and alarm station management
  - Windows®-based administration software has a user friendly GUI to create the Rapid Eye database
  - Can be hosted on a network server using common networked database protocols such as Access, SQL or MSDE
  - Makes controlling and administering a multi-site, multi-user, enterprise-wide system fast, easy and secure

#### VIEW Software

- HRM7VIEW  
(single license included with RU, can also be ordered separately)
- Feature rich, Windows®-based operator software has a user friendly GUI for complete, remote, operations and configuration of one or many different RUs simultaneously
  - Observe and monitor live or recorded video, audio and data from any RU listed in the Site tab. Connect to multiple sites simultaneously using multiple methods from the same or multiple workstations
  - Connect to the same RU site using multiple connection methods
  - Supports LAN/WAN networks and dial-up connections with TCP/IP protocol
  - Control multiple PTZ cameras, monitor 2 independent 2-way audio channels, monitor up to 16 streams of POS, ATM and/or Alarm panel generated data, configure 16 alarm inputs and control 8 auxiliary outputs – all from within a single VIEW session

#### ADMIN and View Workstation Requirements (Minimum requirements)

- IBM-compatible PC
- Windows® 98, NT, ME, 2000 or XP
- Pentium III class or better CPU (600 MHz)
- 128 MB RAM, 256 MB RAM or greater with XP
- 200 MB of free hard disk space, plus adequate storage for video clips
- CD-ROM (for software installation and upgrades)
- Video card(s) and monitor(s) that support XGA mode 1280 x 1024 or SVGA mode 800 x 600 (minimum)
- Mouse or other compatible pointing device

## RAPID EYE™ MULTI-MEDIA DSP

www.honeywellvideo.com

### SYSTEM DIAGRAM

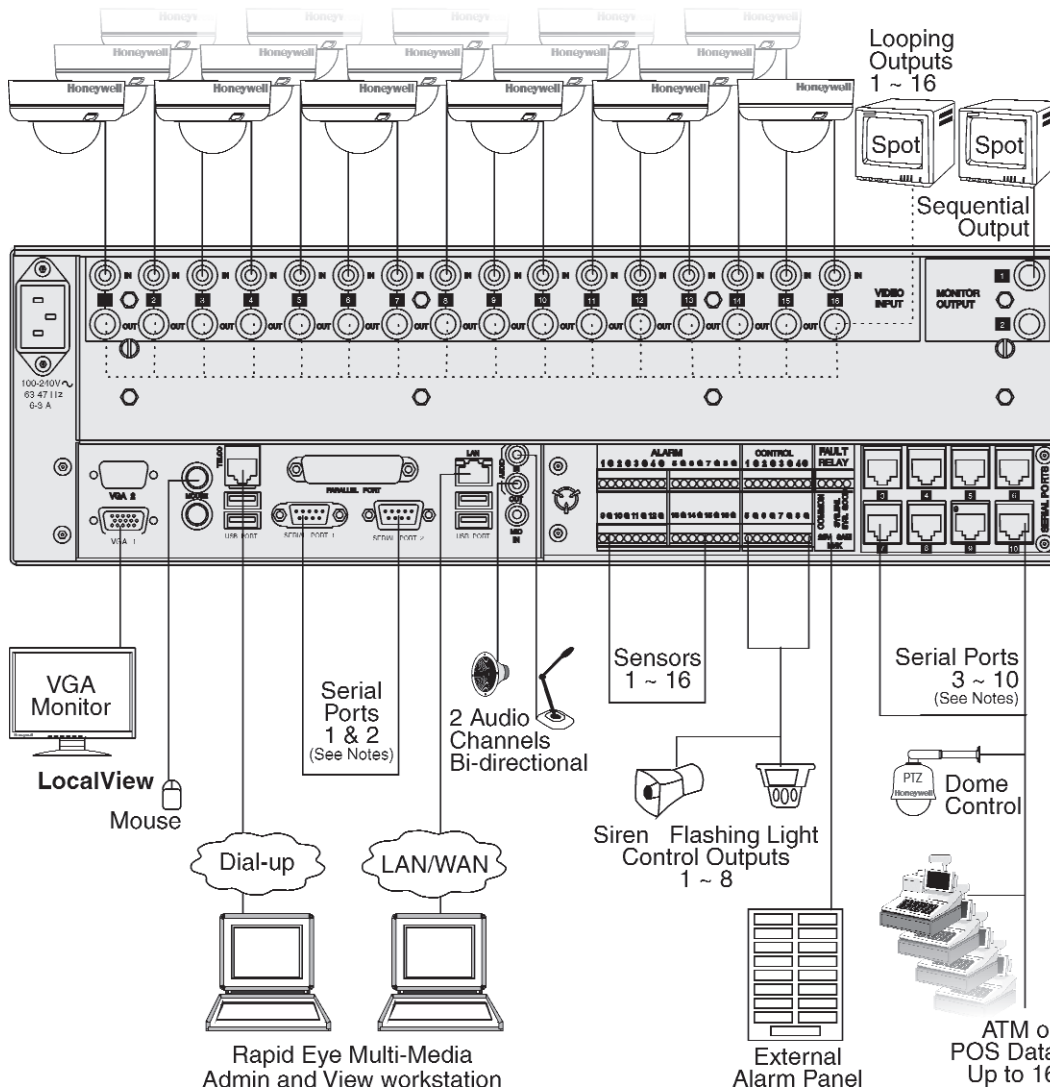

### SYSTEM DIAGRAM NOTES

Serial Port 1:

DB9 (M) RS-232 only; used for data input, external modem or PTZ control with an additional code conversion device

Serial Port 2:

DB9 (M) RS-232 only; HyperTerminal connection, external modem or PTZ control with an additional code conversion device

Serial Ports 3-10:

## RAPID EYE™ MULTI-MEDIA DSP

www.honeywellvideo.com

### SPECIFICATIONS

Rapid Eye VIEW Software	
Sessions	Maximum per RU
Live Video (all users)	32 streams
Video Retrieval (all users)	32 streams
Users Viewing Live Video (and activating outputs)	10 sessions
Users Retrieving Video	10 sessions
Users Accessing Events	10 sessions
Users Accessing Alarms	10 sessions
Users Accessing Maintenance	1 session
Recorder Unit	
Video Standard	NTSC/EIA or PAL/CCIR
Video Format	160 x 120, 320 x 240, 640 x 240, 640 x 480, 704 x 480 (NTSC) 192 x 144, 384 x 288, 704 x 288, 704 x 576 (PAL)
Colors	24-bit true color
Recording and Transmission Compression Algorithm	Modified H.261/263 (REM proprietary)
Record Mode (FIFO)	Continuous buffer
Recording Capacity	250 GB – 2 TB
Recording Rate	480/400 CIF global (NTSC/PAL)
Video Quality Settings	6 – 10 (low – high)
Video Motion Detection	Configurable to sense mass and motion multiple within regions of interest
Video Motion Search	Configurable post event motion search within multiple regions of interest
POS/ATM or Alarm Data	16 – Streams (max)
Event Recording and Reporting	Session, System, Inputs, Outputs, Video, Motion and POS/ATM data
Mass Storage Power Off “Cold Swap”	4 – Field-upgradeable hard drive
Removable Media Power Off “Cold Swap”	1 – Field upgradeable CD/RW bay
Front Panel Control and Display Module (Lockable Front Panel)	Power Switch, 3 – Status LEDs 2 x 16 Status LCD
SNTP Client	Synchronize RU to SMTP servers
DHCP Enabled	Network support for DHCP, WINS or DNS name servers
TCP/IP Port Forwarding	Multiple RUs share same IP Address
PTZ Dome Control	
Local	Mouse control only
Remote	Mouse control and configuration
Protocols Support	7 Major protocols, Over 50 using Bossware (requires additional hardware)

Rear Panel Connections	
Video Input	16 – Looping, BNC 1.0 – Vp-p @ 75 Ohms
Video Output	1 – Spot or switcher, BNC 1.0 – Vp-p @ 75 Ohms
Audio Input/Output	2 – Line level, 3.5 mm jack
Alarm/Control Inputs General Purpose	16 – TTL or 12V level compatible User configurable NO, NC, EOL 3.5 mm terminal block
Control Outputs	8 – TTL or 12V open collector TTL @ +15 mA /-100 mA 12V @ -100 mA current sink 3.5 mm terminal block
Fault Relay	DPDT Form C relay 28 V, 3 A
Serial Ports	2 – RS-232 DB9 (M) 8 – RS-232/422/485 RJ-45
Modem/Telco	V.90 multi-protocol Standard RJ-11 Interface
Networking	10/100 base T Ethernet, Standard RJ-45 Interface
Dual VGA Outputs	800 x 600 monitor LocalView Interface
AC Power	100-240 VAC 50/60 Hz IEC-320 connector Regional power cord included
Electrical	
Input Voltage	115 – 240 VAC, 60 – 50 Hz
Operating Voltage	115V/230V Auto sensing
Power Consumption	350 W
Mechanical	
Dimensions (W x H x D)	17.3" x 5.23" (3U) x 18.8" 440 mm x 133 mm x 478 mm
Weight	Unit: 43 lb (19.5 kg) Shipping: 55 lb (25 kg)
Construction	Housing: Steel chassis
Finish	Housing: Black matte paint
Environmental	
Temperature	Operating: 40°F to 105°F (5°C to 40°C) Storage: 14°F to 150°F (-10°C to 65°C)
Relative Humidity	Operating: 0% - 90%, non-condensing
Regulatory	
Emissions	FCC: Part 15, Class B CE: EN61000-6-3:2001 CE: EN61000-3-2:2000
Immunity	CE: EN50130-4:1995 +A1:1998
Safety U.S. and Canada International	UL, cUL Listed UL 60950-1:2003 IEC/EN 60950-1:2001 CB report and certificate

## RAPID EYE™ MULTI-MEDIA DSP

[www.honeywellvideo.com](http://www.honeywellvideo.com)

### SYSTEM DIMENSIONS

**Front View**

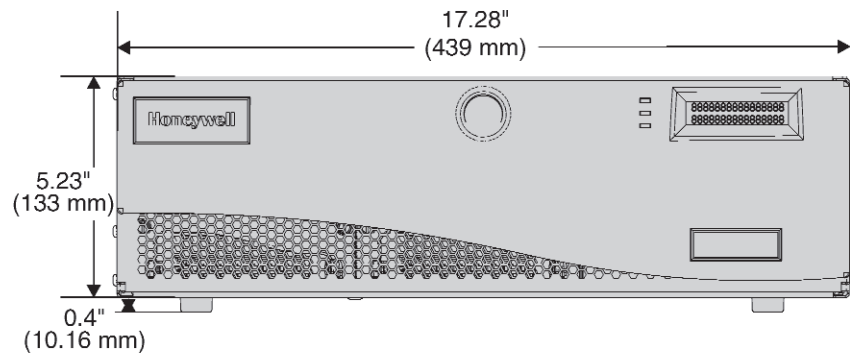

**Back View**

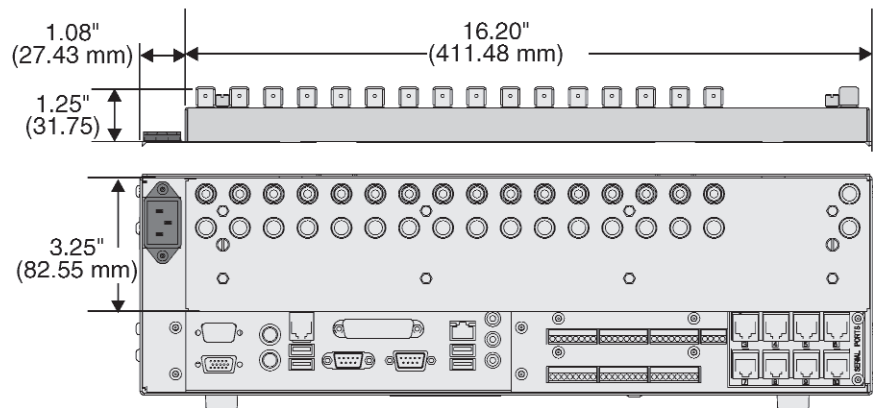

**Side View**

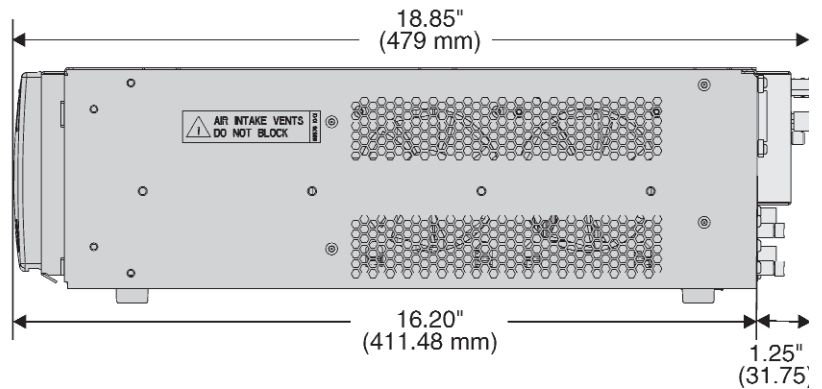

# RAPID EYE™ MULTI-MEDIA DSP

www.honeywellvideo.com

## ACCESSORIES AND ORDERING

Rapid Eye Accessories	
HRMCDRW	REMM CD-RW Drive Kit
HRM7HD250	250 GB Expansion Hard Drive
HRM7HD500	500 GB Expansion Hard Drive
HRM7HD250P	250 GB Program Hard Drive
HRM7HD500P	500 GB Program Hard Drive
HRMSLIDE	Rack Mount Slide Kit
HVBNETPITPOS	Network to Serial Data, POS
AVBPITPOS	Single Port PIT, POS, RS-232/RS-232
AVBPIT4POS	Four Port PIT, POS, RS-232/RS-232

Recommended Accessories	
ACSP1	Camera, Power and Video Surge Protector
ADSP1	Dome, Power, Video and Data Surge Protector
ASP16	RU Battery Backup and Surge Protector
ASP16RMK	Rack Mount Kit for ASP16
Software Part Numbers	
HRM7ADMIN	ADMIN & VIEW Software CD & User Manuals
HRM7VIEW	VIEW Software CD & User Manuals
HRM7CLIP	Clip Player for Windows

Ordering	
<b>HR M 16 B R1 C 250</b>	
	<b>Storage Size</b>
	250 250 GB
	500 500 GB
	750 750 GB
	1T0 1 TB
	1T5 1.5 TB
	2T0 2.0 TB
	<b>Media Options</b>
	C CD-RW
	N NONE
	<b>Record Rate@ Resolution</b>
	R1 480/400 @ CIF
	<b>Video Interface</b>
	B BNC
	<b>#Channels</b>
	16
	<b>Brand or Options</b>
	M North America
	E EMEA
	<b>Model</b>
	Honeywell Rapid Eye

**NOTE:** Honeywell reserves the right, without notification, to make changes in product design or specifications.

### Honeywell Security

Honeywell Video Systems  
 2700 Blankenbaker Pkwy, Suite 150  
 Louisville, KY 40299  
 1.800.796.CCTV  
 www.honeywell.com

HV06060  
 L/REMMDSP/D  
 May 2006  
 © 2006 Honeywell International Inc.

# Honeywell